

客户名称:

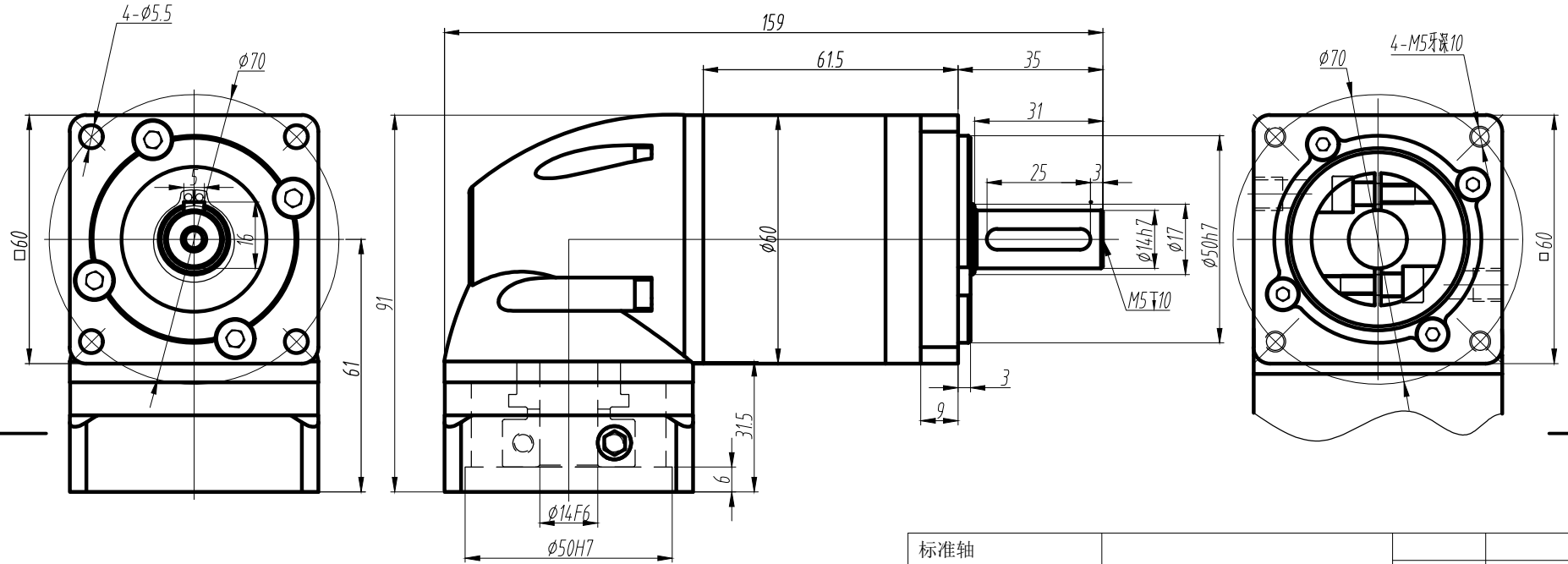

技术参数 technical parameter

额定输出转矩 Nominal torque	_____Nm	最大输出转矩 Max.output torque	_____Nm
额定输入转速 Rated input speed	3000rpm	最大输入转速 Max.input speed	8000rpm
最大径向力 Max.radial force	500N	输出转速50rpm, 输出轴长1/2处为受力 Speed 50rpm,Axial length 1/2 stress	
最大轴向力 Max.axial force	390N	输出转速50rpm, 输出轴长1/2处为受力 Speed 50rpm,Axial length 1/2 stress	
满载效率 Maximum efficiency	88%	使用温度 Operating temp	-25~ +90°
安装方式 Installation method	任意 arbitrarily	润滑方式 Lubrication mode	长效润滑 Permanent lubrication
重量 Weight	1.8 Kg	寿命 Average life span	20000h
防护等级 Protection level	IP65	法兰精度 Flange accuracy	DIN 42955-R
标准侧隙 Standard backlash	≤ 15 arcmin	精密侧隙 Precise backlash	
输出键标准 Key standard	圆头普通平键 Round common flat key (A) GB1096-79		
齿轮精度等级 Gear precision grade	6 GB/T10095-2008		
电机功率 Motor power	400W		
电机安装尺寸 Motor dimensions	φ14*30/φ50*3/4-φ5.5-φ70		

标准轴
Standard output shaft

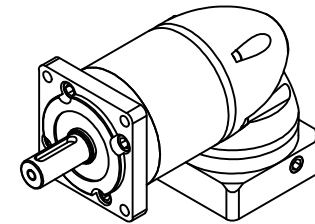
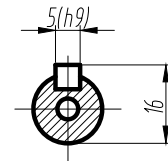

70	24.0
50	33.5
40	31.5
35	33.5
28	31.5
25	33.5
20	31.5
16	31.5
12	31.5
减速比(可选项)	额定转矩(Nm)

广东川铭精工科技
有限公司



标记	处数	分区	更改文件号	签名	年月日
设计			标准化		
审核					
工艺			批准		

数量 重量 比例

TFR060-L2-S2-P2-P
(φ14-φ50-PCD70-M5)

